

ICC-ES Evaluation Report

ESR-1823

Reissued November 1, 2012

This report is subject to renewal February 1, 2014.

www.icc-es.org | (800) 423-6587 | (562) 699-0543

A Subsidiary of the International Code Council®

DIVISION: 06 00 00—WOOD, PLASTICS AND
COMPOSITES

Section: 06 50 000—Structural Plastics

REPORT HOLDER:

FOAM CONCEPTS, INC.
4729 EAST WESLEY DRIVE
ANAHEIM, CALIFORNIA 92807
(714) 693-1037www.styro-loc.com
steve@styro-loc.com

EVALUATION SUBJECT:

STYRO-LOC SYSTEM

1.0 EVALUATION SCOPE

Compliance with the following codes:

- 2006 *International Building Code*® (IBC)

Properties evaluated:

- Structural
- Durability
- Fire performance

2.0 USES

The Styro-Loc System is used as an exterior parapet wall architectural detailing system on Type V construction under the IBC and UBC, and any construction in accordance with the IRC.

3.0 DESCRIPTION

3.1 General:

The Styro-Loc System components include foam plastic shapes with factory-installed Styro-Loc Inserts, adhesive, steel straps, metal flashing, and EIFS lamina. See Figure 1 for an illustration of the system.

3.2 Foam Plastic Shapes with Styro-Loc Insert:

The foam plastic shapes are factory-cut from Type I expanded polystyrene foam plastic boards complying with ASTM C 578 and recognized in a current ICC-ES evaluation report. The Styro-Loc Insert is formed from No. 24 gage thick [0.024 inch (0.61 mm)] steel conforming to

ASTM A 653 or ASTM A 1008, having mechanical properties as set forth in the approved quality documentation, and having a minimum G90 galvanized coating designation. The Styro-Loc Insert's length is continuous along the foam shape length. The dimensions and shape of the Styro-Loc Insert are shown in Figure 2.

During the forming process, the Styro-Loc Insert is positioned a maximum of 2¹/₂ inches (64 mm) from the outer edge of the foam plastic shape. Additional Styro-Loc Inserts are inserted in the foam shape when the horizontal dimension is greater than 14 inches, as shown in Table 1. The spacing of the Styro-Loc Inserts is as shown in Figure 3.

The shapes are either coated at the jobsite with the Omega Products International, Inc., Akroflex exterior insulation and finish system recognized in evaluation report [ESR-2064](#) and [ESR-2305](#), or are factory-coated with a base coat and reinforcing fabric recognized in evaluation report [ESR-2064](#) and [ESR-2305](#), with the finish coat applied at the jobsite. The dimensions of the shapes are shown in Table 1 of this report.

3.3 Adhesive:

The adhesive used to adhere the foam plastic shape to the wall surface must be Omega Products International, Inc., Styro-Glue Dry Bond, Styro-Glue, Styro-Glue TF or Styro-Bond adhesive recognized in ICC-ES evaluation report [ESR-2064](#) and [ESR-2305](#).

3.4 Steel Straps:

Steel straps used to secure flashing to the foam plastic shape are minimum 2-inch-wide (51 mm), No. 16 gage [0.060-inch-thick (1.50 mm)] steel conforming to ASTM A 653 SS Grade 50 Class I galvanized steel, having a G90 coating designation.

3.5 Metal Cap Flashing:

Flashing must be minimum ASTM A 653 SS Grade 50 Class I, No. 24 gage [0.024 inch (0.61 mm)] galvanized steel flashing complying with the IBC, and must be formed to engage the end of the steel straps as shown in Figure 1.

3.6 EIFS Lamina:

The exposed surfaces of the foam plastic shape must be coated with the Omega Products International, Inc., Akroflex exterior insulation and finish system lamina recognized in ICC-ES evaluation reports [ESR-2064](#) and [ESR-2305](#). The EIFS lamina includes the basecoat, reinforcing fabric, and finish coating.

4.0 DESIGN AND INSTALLATION

4.1 Styro-Loc System:

The foam plastic shapes incorporating the Styro-Loc Inserts must be supplied to the jobsite by Foam Concepts, Inc. The surface of the parapet wall must be prepared as required by the applicable code, with first and second coats of exterior plaster (stucco) complying with Chapter 25 of the IBC, Chapter 7 of the IRC, or Chapter 25 of the UBC, applied in accordance with the applicable code. Each foam plastic shape incorporating the Styro-Loc Inserts must be adhered to the exterior side of the stuccoed parapet wall using one of the adhesives described in Section 3.3. The Styro-Loc Inserts must be positioned 2½ inches (64 mm) from the outer edge of the foam plastic shape and spaced at a maximum of 6 inches (152 mm) on center. The adhesive must be prepared and applied to the foam plastic shape in accordance with ICC-ES evaluation report [ESR-2064](#) or [ESR-2305](#). The exposed surfaces of the foam plastic shape must be coated with the Akroflex EIFS lamina in accordance with ICC-ES evaluation report [ESR-2064](#) or [ESR-2305](#).

The steel straps must be positioned over the top of the parapet wall and attached to the parapet wall framing with 7/8-inch-long (22 mm), hex-head, self-drilling, corrosion-resistant screws having 0.125-inch-diameter (3.2 mm) shanks. The straps must be located 12 inches (305 mm) from either end of the foam plastic shape and must be spaced a maximum of 23 inches (584 mm) on center. See Figure 1 for locations of the steel straps. The steel straps must be fastened to the Styro-Loc Insert using 0.125-inch-diameter-shank-by-7/8-inch-long (3.2 mm by 22 mm) corrosion-resistant screws. The steel straps must be bent over the foam plastic shape, extending down 3 inches (76 mm), and must be bent outwards approximately ½ inch (12.7 mm) to receive the flashing.

The flashing must be installed over the parapet wall and foam plastic shape as required for conventional construction, and the flashing must engage the bent ends of the metal straps a minimum of ½ inch (12.7 mm).

Locations for expansion and control joints must be determined and must be installed as specified by the architect, designer, builder or Foam Concepts, Inc., in that order. Construction joints must be installed in accordance with Foam Concepts, Inc., published installation instructions.

4.2 Structural Capacity:

The maximum allowable concentrated vertical load on the foam plastic shape is 600 pounds (2.7 kN). Applied concentrated loads must be uniformly applied over a minimum area of 0.67 square feet (0.062 m²). The system has an allowable wind uplift capacity of 15 psf (0.72 kPa). The capacity of the installed foam plastic shape to resist a sustained loading condition is outside the scope of this report.

5.0 CONDITIONS OF USE

The Styro-Loc System described in this report complies with, or is a suitable alternative to what is specified in, those codes listed in Section 1.0 of this report, subject to the following conditions:

- 5.1** Installations must comply with this report, the manufacturer’s published installation instructions, and the applicable code. In the event of a conflict between this report and the manufacturer’s published installation instructions, this report governs.
- 5.2** The system must be installed by a contractor recognized by Foam Concepts, Inc., as being qualified to perform such installations.
- 5.3** An installation card confirming compliance with exterior coating report [ESR-2064](#) or [ESR-2305](#) must be completed by the contractor and presented to the code official at the end of each project.
- 5.4** The foam plastic shapes are manufactured by Foam Concepts, Inc., in Anaheim, California, under a quality control program with inspections by R. I. Ogawa & Associates, Inc. (AA-705).

6.0 EVIDENCE SUBMITTED

Data in accordance with the ICC-ES Acceptance Criteria for Foam Plastic Shapes for Parapet Applications (AC161), dated February 2008.

7.0 IDENTIFICATION

Each package of the Styro-Loc system components must be identified by a label bearing the company name (Foam Concepts, Inc.) and address, the product name, the production date, the name of the inspection agency [R. I. Ogawa & Associates, Inc. (AA-705)] and the ICC-ES evaluation report number (ESR-1823). The adhesive and EIFS lamina components must be labeled in accordance with [ESR-2064](#) or [ESR-2305](#).

TABLE 1—STYRO-LOC FOAM SHAPE SYSTEM CONFIGURATIONS

FOAM SHAPE DIMENSIONS		NUMBER OF STYRO-LOC INSERTS ¹
Width, <i>b</i> (inches)	Depth, <i>d</i> (inches)	
24	24	3
22	22	3
20	20	2
18	18	2
16	18	2
14	18	1
12	18	1

For **SI**: 1 inch = 25.4 mm.

¹Styro-Loc Inserts must be spaced 2½ inches from the edge of the foam shape and must be spaced a maximum of 6 inches from one other.

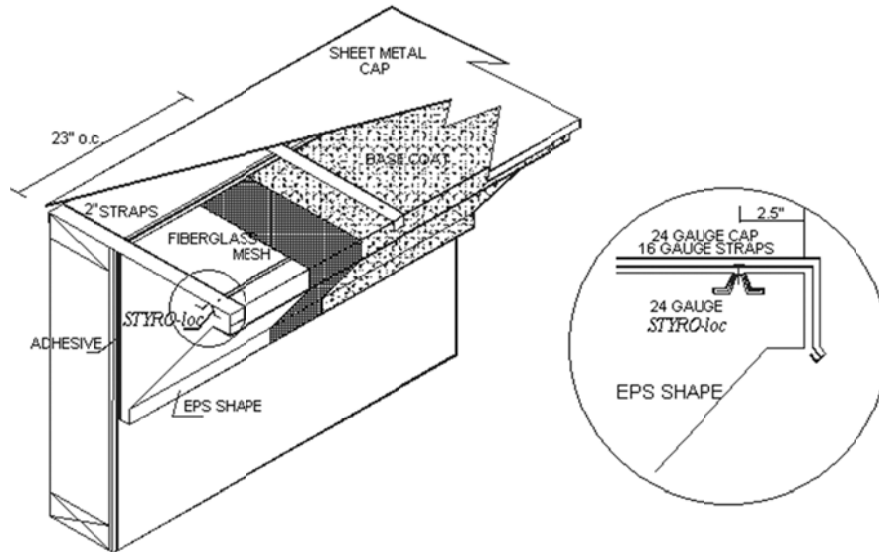
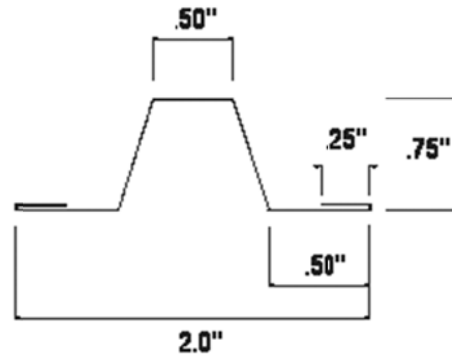

FIGURE 1—STYRO-LOC SYSTEM



FIGURE—2 STYRO-LOC INSERT

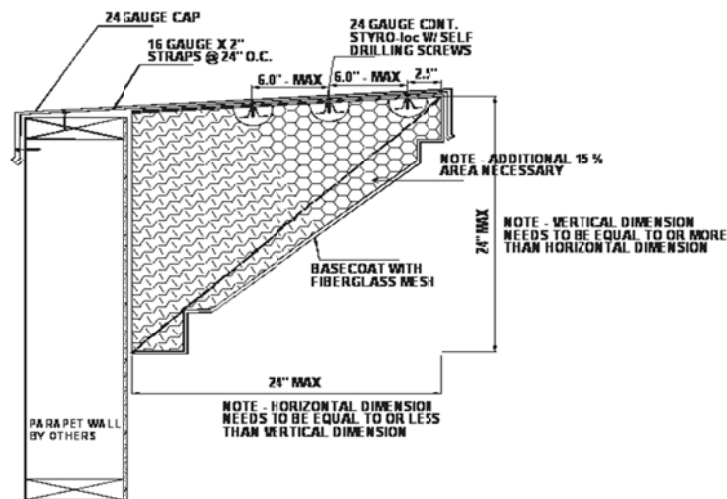

FIGURE 3—SPACING OF STYRO-LOC INSERTS